

S1D13705 Embedded Memory LCD Controller

The S1D13705 is a color/monochrome LCD graphics controller with an embedded 80K Byte SRAM display buffer. The high integration of the S1D13705 provides a low cost, low power, single chip solution to meet the requirements of embedded markets such as Office Automation equipment, Mobile Communications devices, and Palm-size PCs where board size and battery life are major concerns.

Products requiring a "Portrait" display can take advantage of the Hardware Portrait Mode feature of the S1D13705. Virtual and Split Screen are just some of the display modes supported. While focusing on devices targeted by the Microsoft Windows CE Operating System, the S1D13705's impartiality to CPU type or operating system makes it an ideal display solution for a wide variety of applications.

■ FEATURES

- Embedded 80K byte SRAM display buffer.
- Direct support for the following CPU's:
 - Hitachi SH-3.
 - Hitachi SH-4.
 - Motorola M68xxx.
- MPU bus interface with programmable READY.
- Resolutions up to:
 - 640x480 at a color depth of 2 bpp.
 - 640x240 at a color depth of 4 bpp.
 - 320x240 at a color depth of 8 bpp.
- Up to 256 simultaneous colors from a possible 4096 colors on passive LCD panels and active matrix TFT/D-TFD LCD panels.
- Register level support for EL panels.
- Hardware Portrait Mode
- Split Screen Display
- Virtual Display Support
- LCD power-down sequencing.

■ SYSTEM BLOCK DIAGRAM

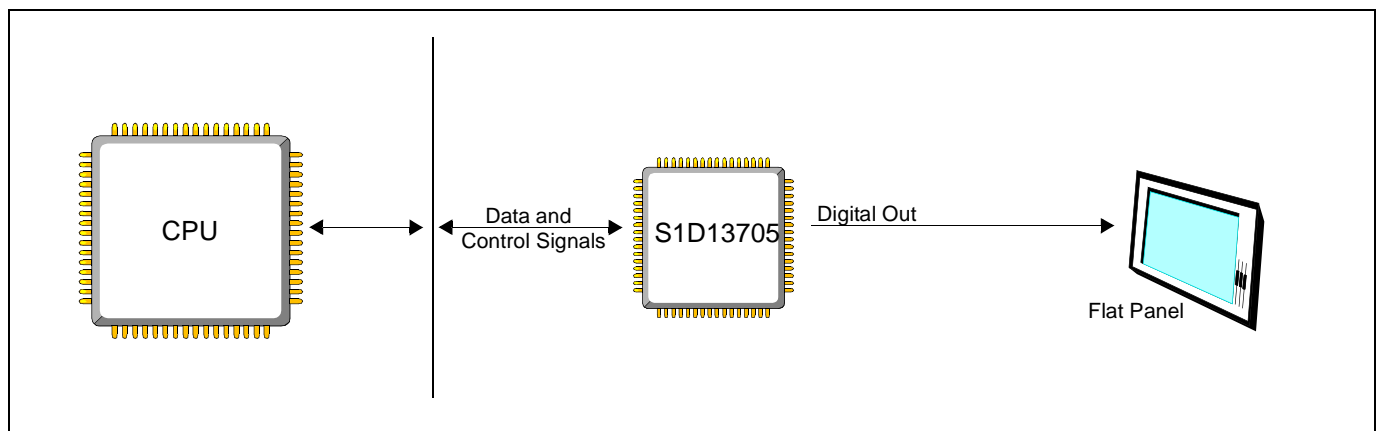

DESCRIPTION

Memory Interface

- Embedded 80K byte SRAM display buffer.

CPU Interface

- Direct support for:
 - Hitachi SH-3.
 - Hitachi SH-4.
 - Motorola M68xxx.
- MPU bus interface with programmable READY.
- CPU write buffer.

Display Support

- 4/8-bit monochrome LCD interface.
- 4/8-bit color LCD interface.
- Single-panel, single-drive passive displays.
- Dual-panel, dual-drive passive displays.
- Active matrix TFT / D-TFD interface.
- Example resolutions:
 - 640x480 at a color depth of 2 bpp.
 - 640x240 at a color depth of 4 bpp.
 - 320x240 at a color depth of 8 bpp.

Clock Source

- Single clock input for both pixel and memory clocks.
- The S1D13705 clock source can be internally divided down for a higher frequency clock input.
- Dynamic switching of memory clocks in portrait mode.

Display Modes

- 1/2/4/8 bit-per-pixel (bpp) support on LCD.
- Up to 16 shades of gray using FRM on monochrome passive LCD panels.
- Up to 256 simultaneous colors from a possible 4096 colors on passive STN and active matrix TFT/D-TFD LCD panels.
- Split Screen Display: allows two different images to be simultaneously viewed on the same display.
- Virtual Display Support: displays images larger than the display size through the use of panning.
- Double Buffering/multi-pages: provides smooth animation and instantaneous screen update.
- Hardware Portrait Mode: direct hardware 90° rotation of display image for portrait mode display.

Power Down Modes

- Software Suspend mode.
- LCD power-down sequencing.

Operating Voltage

- CORE_{VDD} 2.7 to 3.6 volts; IO_{VDD} 2.7 to 5.5 volts.

Package

- 80-pin QFP14.

CONTACT YOUR SALES REPRESENTATIVE FOR THESE COMPREHENSIVE DESIGN TOOLS:

- S1D13705 Technical Manual
- S5U13705 Evaluation Boards
- Windows[®] CE Display Driver
- CPU Independent Software Utilities

FOR SYSTEM INTEGRATION SERVICES FOR WINDOWS[®] CE CONTACT:

Epson Research & Development, Inc.
 Suite #320 - 11120 Horseshoe Way
 Richmond, B.C., Canada V7A 5H7
 Tel: (604) 275-5151
 Fax: (604) 275-2167
 Email: wince@erd.epson.com
<http://www.erd.epson.com>



Japan

Seiko Epson Corporation
 IC International Sales Group
 421-8, Hino, Hino-shi
 Tokyo 191-8501, Japan
 Tel: 042-587-5812
 Fax: 042-587-5564
<http://www.epson.co.jp/>

Hong Kong

Epson Hong Kong Ltd.
 20/F., Harbour Centre
 25 Harbour Road
 Wanchai, Hong Kong
 Tel: 2585-4600
 Fax: 2827-4346
<http://www.epson.com.hk/>

North America

Epson Electronics America, Inc.
 2580 Orchard Parkway
 San Jose, CA 95131, USA
 Tel: (408) 922-0200
 Fax: (408) 922-0238
<http://www.eea.epson.com/>

Europe

Epson Europe Electronics GmbH
 Riesstrasse 15
 80992 Munich, Germany
 Tel: 089-14005-0
 Fax: 089-14005-110
<http://www.epson-electronics.de/>

Taiwan

Epson Taiwan Technology & Trading Ltd.
 14F, No. 7
 Song Ren Road
 Taipei 110
 Tel: 02-8786-6688
 Fax: 02-8786-6677
<http://www.epson.com.tw/>

Singapore

Epson Singapore Pte Ltd
 1 HarbourFront Place #03-02
 HarbourFront Tower One
 Singapore, 098633
 Tel: (65) 6586-5500
 Fax: (65) 6271-3182
<http://www.epson.com.sg/>

© SEIKO EPSON CORPORATION 2001-2007. All rights reserved. VDC
 Information in this document is subject to change without notice. You may download and use this document, but only for your own use in evaluating Seiko Epson/EPSON products. You may not modify the document. Epson Research and Development, Inc. disclaims any representation that the contents of this document are accurate or current. The Programs/Technologies described in this document may contain material protected under U.S. and/or International Patent laws. EPSON is a registered trademark of Seiko Epson Corporation. Microsoft, Windows, and the Windows CE Logo are registered trademarks of Microsoft Corporation.